

Vision Punch Bender - Topaz Smart VPB

Salient Features

- Fully automatic vision punch bender
- High resolution cameras with PLC controls
- Three cycle alignment for most accurate positioning
- User settable punch and bend position for each plate type
- Caters up to 4 plate sizes (with different bend & punch)
- Hand shaking with plate processors for line status
- Inline capable plate flow
- Servo driven anvil & aligner bed
- Half plate accepted

Universal anvil
with
programmable
plate sizes

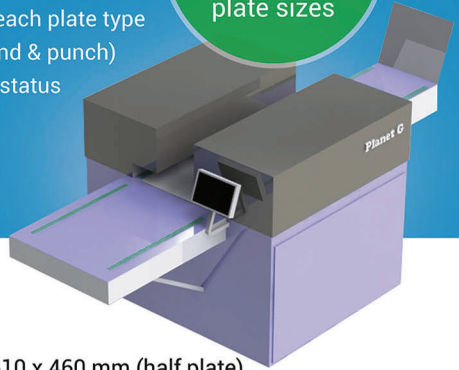

Technical Specifications

- Max Plate Thickness: 0.3 mm
- Max Plate Size: 610 x 920 mm (full plate); 610 x 460 mm (half plate)
- Min Plate Size: 560 x 690 mm (full plate); 560 x 345 mm (half plate)
- Max Depth of Punch: 15 mm (customization possible)
- Max Bend Angle: 35 degrees (inside)
- Max Number of Bends: 2 programmable on both edges
- Positioning Accuracy: 25 microns
- Number of Plate Types: 4
- Weight: 650 kgs
- Dimensions: 1500 x 1250 x 1250 mm (L x W x H)
- Power: 2 KW, 1 Phase, 230 V, 50 Hz
- Compressed Air: 6 Bar, 30 LPM

Upgrade Options

- Inline plate flow with stacker
- Multi-stacker for different plate types
- Automatic plate type detection with barcode reader
- In feed conveyor